

Product Overview

Catco catalytic heaters bring fuel and oxygen together in the presence of a heated catalyst. This causes a chemical reaction that produces infrared heat but no flame. Once operational, a catalytic heater can operate indefinitely if it has a clean source of fuel and sufficient air.

The 6x6 heater is most often used as the heat source for many of Catco's most popular heated enclosure packages which prevent valves and regulators from freezing. It can also be used to heat drip pots and filters, and for space heating in small areas or instrumentation and measurement enclosures.

Popular Applications

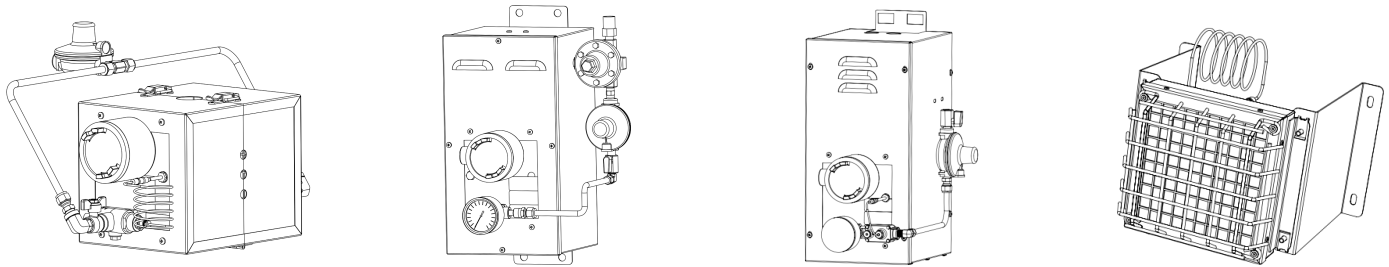

Part Number Key

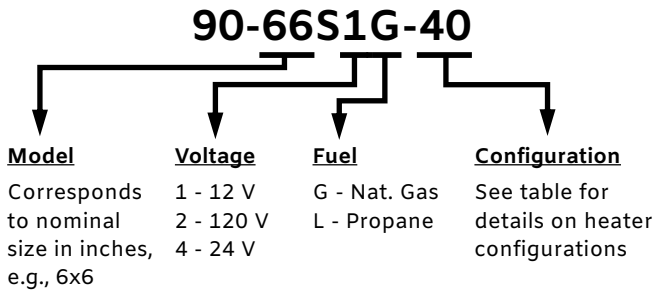

Heater Configurations

Config	Hazardous Location Listing		Junction Box		Valve and Thermo-couple
	Class I Div 1 Group D	Class I Div 2 Group D	Plain	EP	
-10			•		
-20				•	
-30		FM	•		•
-40	FM	FM		•	•
-50	CSA	CSA		•	•

Product Specs

Rating BTU/hr (kW)	Fuel Consumption	
	Natural Gas SCFH (m3/hr)	Propane lb/hr (kg/hr)
1500 (0.44)	1.5 (0.04)	0.07 (0.03)

Starting Amperage, A		
12 V	24 V	120 V
6.7	4.2	0.6

Accessories

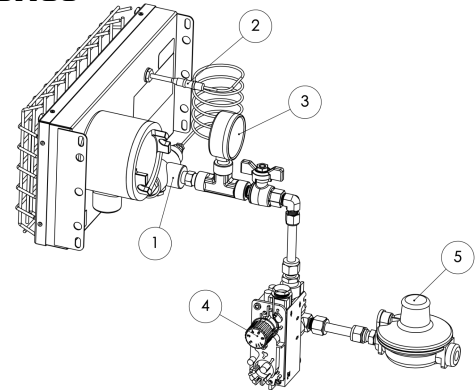

	Part Number	Description
1	30-127	Shutoff valve (aka safety valve)
2	30-010	Thermocouple
3	35-076	Water column pressure gauge
4	40-037-G1500	Thermostat (natural gas)
5	50-005	912 style low-pressure regulator
	20-030	12 V starting cables (plain junction box)
	20-031	12 V starting cables (EP junction box)

For additional accessories and more information, see the Catalytic Heater Product Bulletin.